

**EXPANSION JOINT EPDM OR NBR PN10/16**

ISO 9001

BUREAU VERITAS  
Certification



**Size :** DN 32 to 600  
**Ends :** Flanges PN10/16  
**Min Temperature :** - 10°C  
**Max Temperature :** + 100°C for EPDM and + 80°C for NBR  
**Max Pressure :** 16 Bars up to DN 300  
**Specifications :** Absorb vibrations and noises  
Linear and angular compansion  
Single sphere

**Materials :** Electro galvanized steel flanges

## EXPANSION JOINT EPDM OR NBR PN10/16

**SPECIFICATIONS :**

- Absorb vibration, noises and expansion
- Linear and angular compansion
- Tube EPDM ( EPDM marking ) or NBR ( NBR marking )
- Electro galvanized steel flanges PN10/16
- Expansion limiter ( option )

Marking example ( EPDM ) :



**USE :**

- Water distribution ( for EPDM types )
- Oil, hydrocarbon, air ( for NBR types )
- Min and max Temperature Ts : - 10°C to + 100°C for EPDM types ( Ref.1501 and 1502 )
- Min and max Temperature Ts : - 10°C to + 80°C for NBR type ( Ref.1503 )
- Max Pressure Ps : 16 bars up to DN300 ( see graph ) , 10 bars over

**PRESSURE / TEMPERATURE GRAPH (STEAM EXCLUDED ) REF. 1501-1502 DN 32 – DN 300 :**

### 1501-1502 DN 32 – DN 300

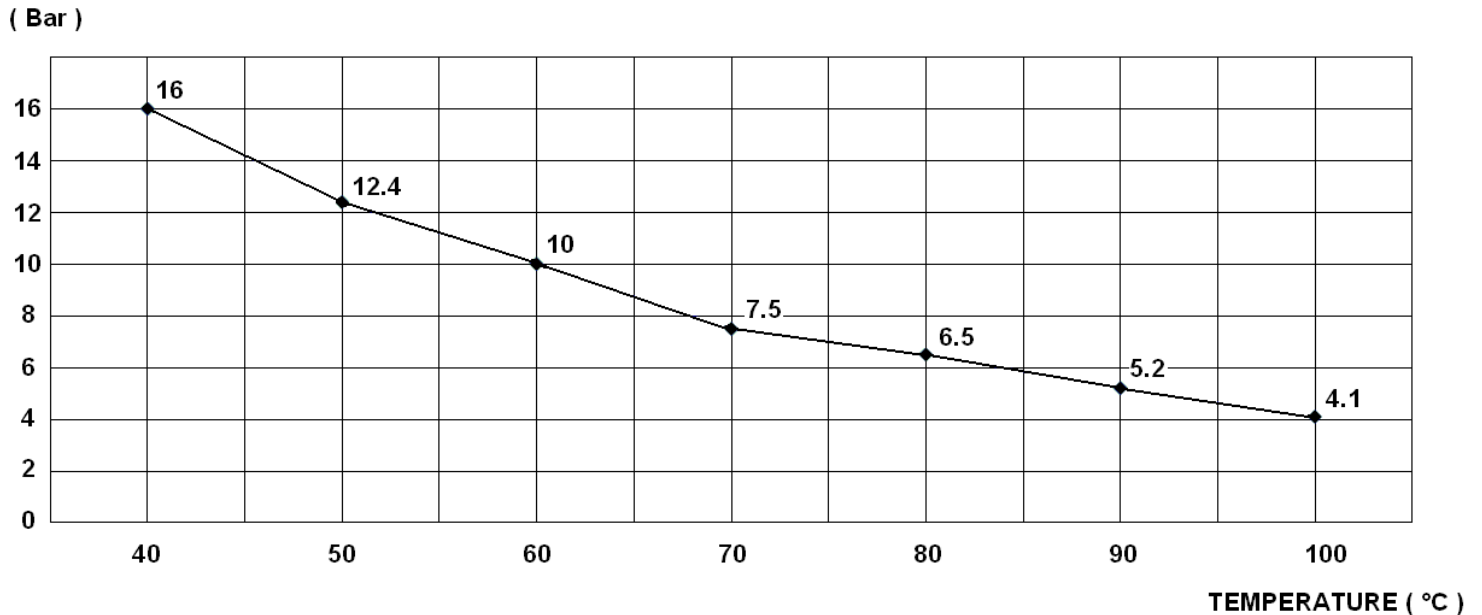

**EXPANSION JOINT EPDM OR NBR PN10/16**

PRESSURE / TEMPERATURE GRAPH (STEAM EXCLUDED ) REF. 1501-1502 DN 350 – DN 600 :

**1501-1502 DN 350 – DN 600**

( Bar )

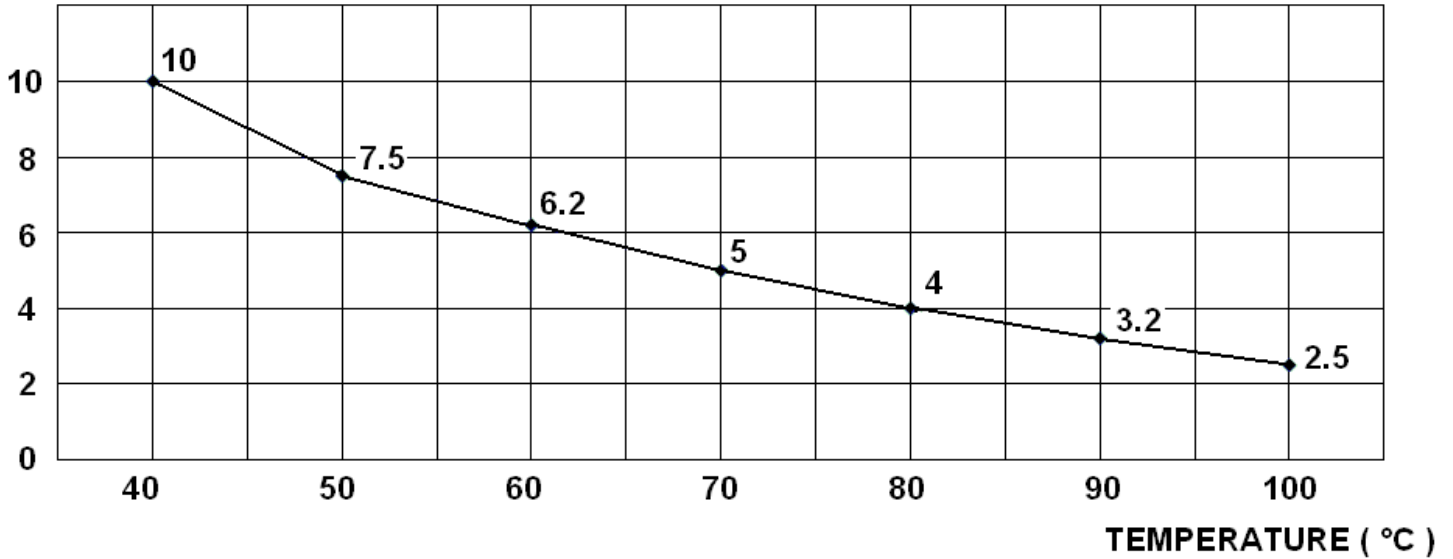

PRESSURE / TEMPERATURE GRAPH (STEAM EXCLUDED ) REF. 1503 DN 32 - 200 :

**1503 DN 32 – DN 200**

( Bar )

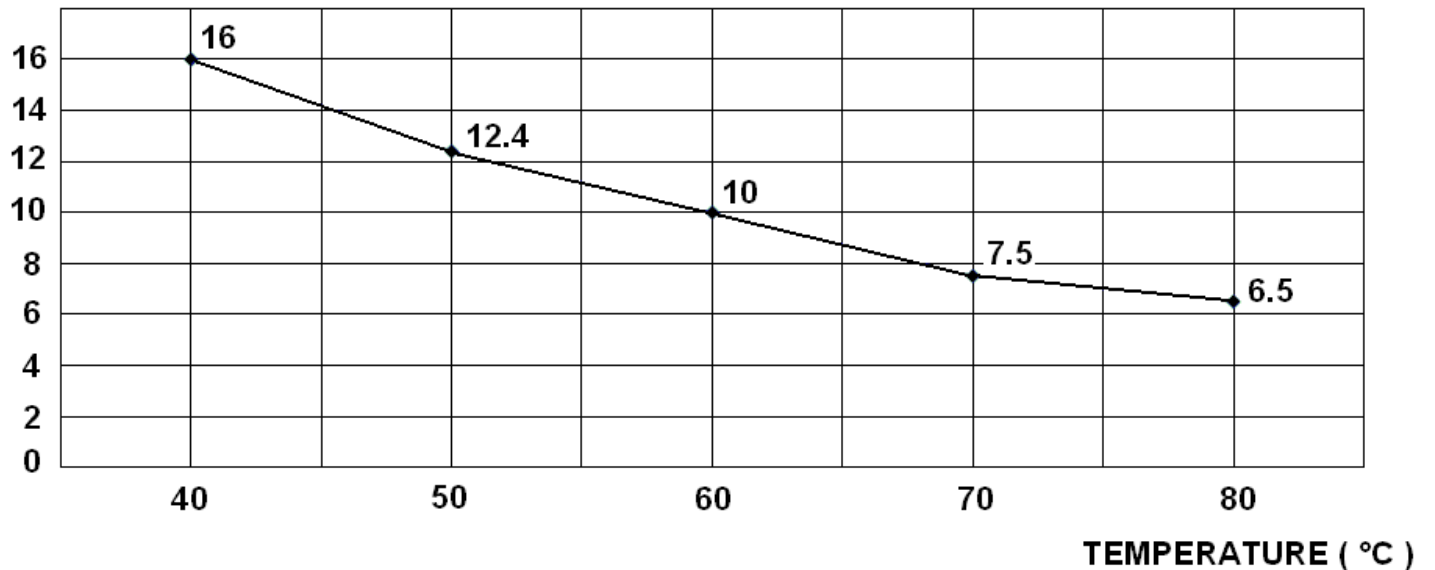

## EXPANSION JOINT EPDM OR NBR PN10/16

### RANGE :

- EPDM expansion joint with steel flanges PN10 from DN 32 to DN 600 **Ref. 1501**
- EPDM expansion joint with steel flanges PN16 from DN 200 to DN 300 **Ref. 1502**
- NBR expansion joint with steel flanges PN10 from DN 32 to DN 200 **Ref. 1503**
- Expansion limiter ( with 2 studs and 4 plates included ) PN10 from DN 32 to DN 600 **Ref. 98604**
- Expansion limiter ( with 2 studs and 4 plates included ) PN16 from DN 200 to DN 300 **Ref. 98603**

### MATERIALS :

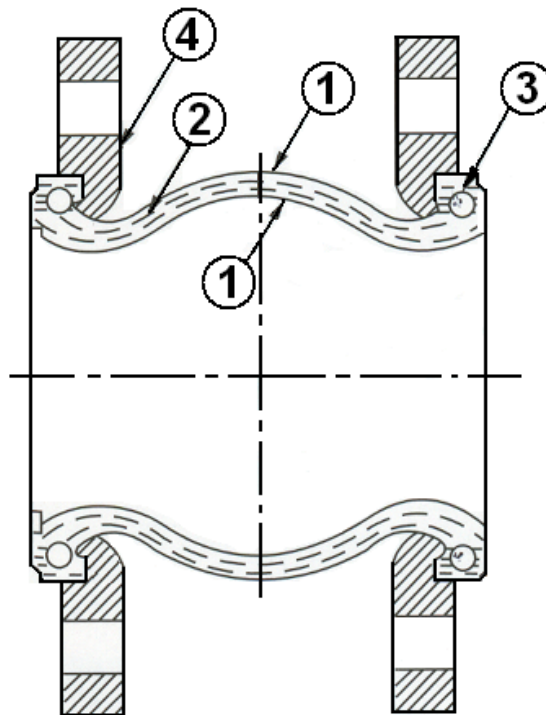

Item	Designation	Materials 1501 - 1502	Materials 1503
1	Inner tube and cover	EPDM	NBR
2	Reinforcement	Nylon cord	
3	Brace	Hard steel	
4	Flanges	Electro galvanized steel	

**EXPANSION JOINT EPDM OR NBR PN10/16**

SIZE ( in mm ) :

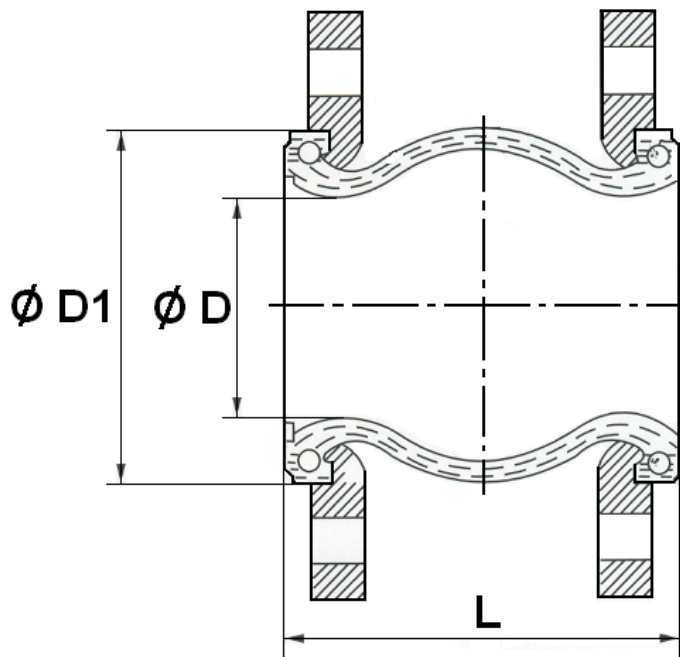

Ref.	DN	32	40	50	65	80	100	125	150	200	250	300	350	400	450	500	600
1501-1502	L	95	95	105	115	130	135	170	180	205	240	260	265	265	200	200	250
	$\varnothing D$	29	37	47	57	74	91	119	145	199	241	294	331	372	431	486	591
1503	$\varnothing D1$	69	79	90	108	124	145	179	209	261	320	370	420	473	532	587	685
1501	Weig. ( Kg )	2.79	3.59	4.23	4.74	6.27	6.47	9.4	12.75	17.73	23.27	29.4	41.3	46.85	55.18	65	74.5
1502	Weig. ( Kg )									17.87	26	33.13					
1503	Weig. ( Kg )	2.95	3.46	3.98	4.89	6.57	6.74	9.36	12.71	16.80							

**EXPANSION JOINT EPDM OR NBR PN10/16**

FLANGES SIZE PN10 Ref.1501 and 1503 ( in mm ) :

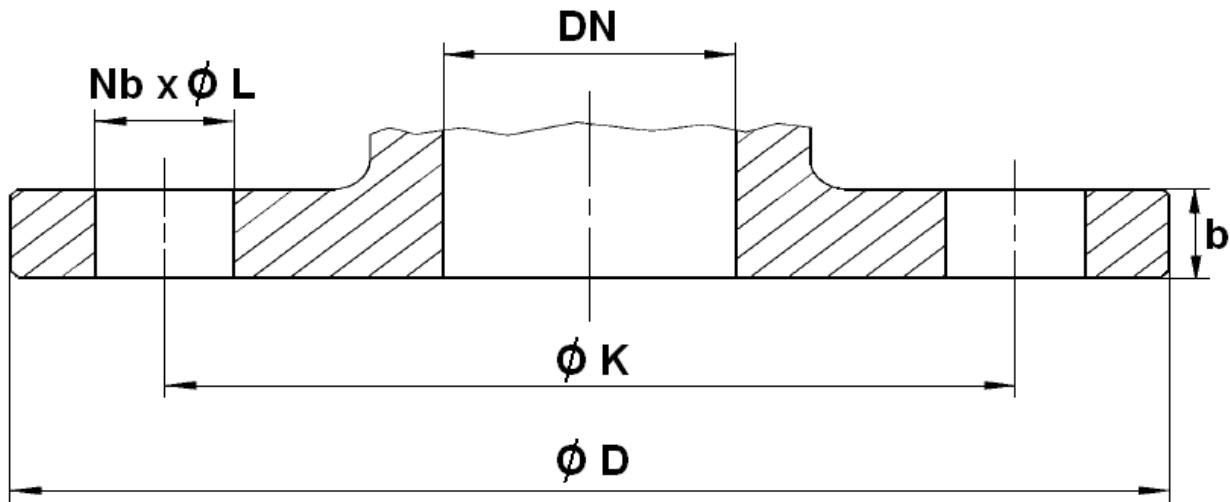

Ref.	DN	32	40	50	65	80	100	125	150	200	250	300
1501 1503	$\varnothing D$	140	150	165	185	200	220	250	285	340	395	445
	$\varnothing K$	100	110	125	145	160	180	210	240	295	350	400
	Nb x $\varnothing L$	4 x 19	4 x 19	4 x 19	4 x 19	8 x 19	8 x 19	8 x 19	8 x 23	8 x 23	12 x 23	12 x 23
	b	14	14	15	15	17	17	19	19	20	22	22

Ref.	DN	350	400	450	500	600
1501 1503	$\varnothing D$	505	565	615	670	780
	$\varnothing K$	460	515	565	620	725
	Nb x $\varnothing L$	16 x 23	16 x 28	20 x 28	20 x 28	20 x 31
	b	26	28	28	30	32

**EXPANSION JOINT EPDM OR NBR PN10/16**

FLANGES SIZE PN16 Ref.1502 ( in mm ) :

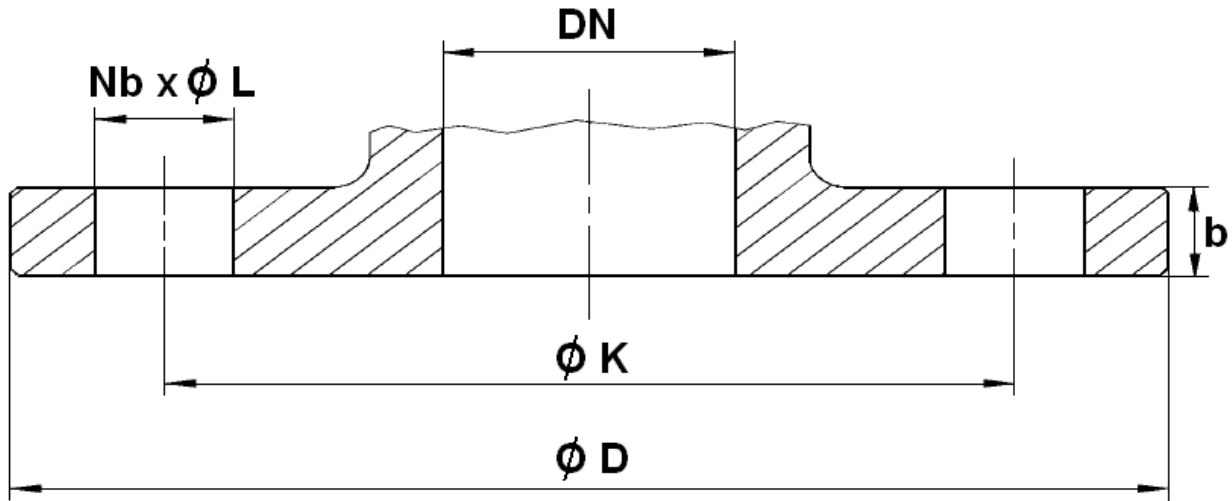

Ref.	DN	200	250	300
1502	Ø D	340	405	460
	Ø K	295	355	410
	Nb x Ø L	12 x 23	12 x 28	12 x 28
	b	22	24	24

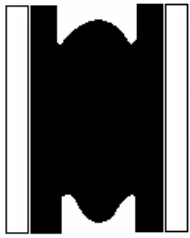
**EXPANSION JOINT EPDM OR NBR PN10/16**
**MOVEMENTS ( in mm ) :**

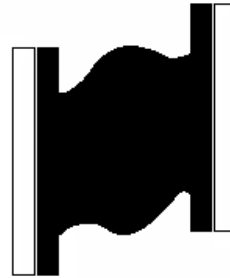
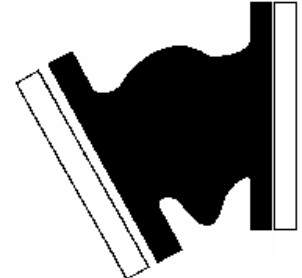
**Compansion**

**Expansion**

**Lateral**

**Angular**

DN	32	40	50	65	80	100	125	150	200	250	300	350	400	450	500	600
Compansion	8	8	8	12	12	18	18	18	20	22	24	25	25	20	20	20
Expansion	4	4	4	6	10	10	10	10	14	14	14	16	16	12	12	12
Lateral	8	8	8	10	12	12	12	12	18	18	18	18	18	18	18	18
Angular	15°	15°	15°	15°	15°	15°	15°	15°	15°	15°	15°	15°	15°	15°	15°	15°

**Maximum movements can't be applied together**

**STANDARDS :**

- Fabrication according to ISO 9001 : 2008
- DIRECTIVE 2014/68/EU : Products excluded from directive (Article 4, § 3)
- Flanges according to EN 1092-1 PN10/16

**ADVICE :** Our opinion and our advice are not guaranteed and SFERACO shall not be liable for the consequences of damages. The customer must check the right choice of the products with the real service conditions.



**EXPANSION JOINT EPDM OR NBR PN10/16**

**INSTALLATION INSTRUCTION :**

Expansion joint are designed for the absorption of previously specified movements under specific pressure and temperature conditions. So that the maximum service life is achieved, the following items must be observed during installation.

- Prior to fitment of the compensator it must be ensured that :
  - The route of the pipeline is straight - The expansion tallies with that of the chosen compensator
  - The expansion tallies with that of The chosen compensator
  - The fixes points are dimensionned so that they can absorb the reaction forces and stiffness rate that arise during use.
  - The pipeline is limited by fixed points
  - The distance between compensator and bearing may be a maximum of 3 times the pipe diameter. Place only one compensator between 2 bearings.
- Each pipe elbow must be fixed by support, specially if compensator is mounted with limiters. Fixed bearings are necessary because compensator is submitted to expansion when it is under pressure.
- Expansion joint must not be painted and heat-insulated. It must be protected from bad weather and solar radiation.
- During assembly operation, make sure screws are oriented according to the graph out below :

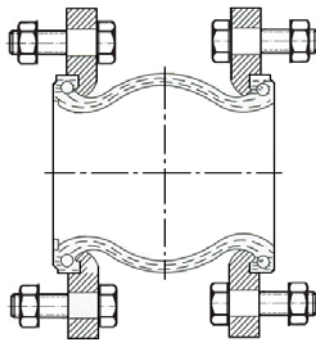

- Please apply the following stages order :
  - a) Fixed points for above pipeline
  - b) Fixed points for down pipeline
  - c) Compensator mounting
- Installation layout :

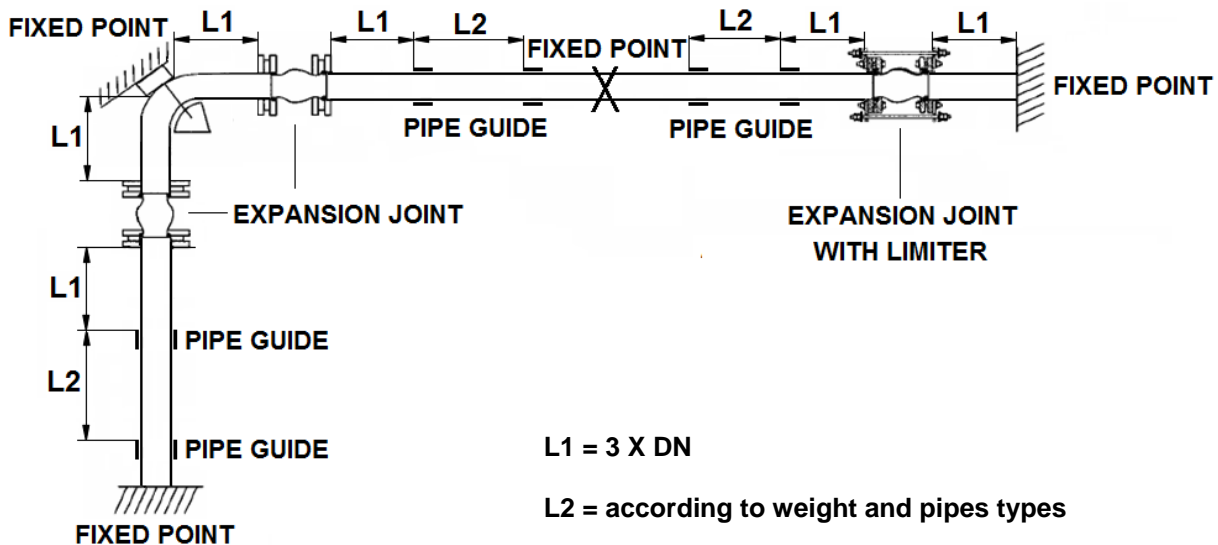

## EXPANSION JOINT EPDM OR NBR PN10/16

### INSTALLATION INSTRUCTION ( SUITE ) :

- Check that the compensator is not subjected to the weight of the pipeline. The installation length must agree with the installation gap. The compensator must never be twisted. It is recommended that specific characteristics be observed during maintenance :
  - The compensator must never be painted or recovered by heat insulation
  - The tightness of the bolts must be checked often.
  - The flanges must be perfectly cleared
  
- Use limiters : When the working pressure can exceed the following values :
  - Up to DN100 : 10 bars
  - From DN125 to DN250 : 9 bars
  - From DN300 to DN350 : 6 bars
  - From DN400 to DN600 : 3 bars
  - When there is some risk of high pressure (pump starting) or high temperature.

**NOTA :** The life of compensator can vary because of working conditions (fluids, pressure, temperature), that is why it is necessary to check it regularly.

#### WRONG INSTALLATION :

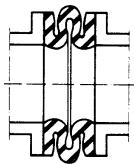

Excessive compansion

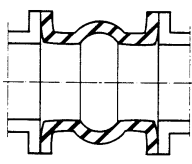

Excessive expansion

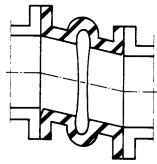

Cutting too important

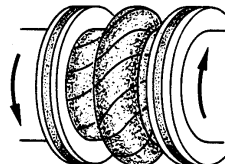

Torsion

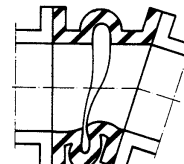

Important compansion and angular deviation

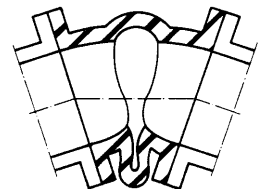

Angular deviation too important